

Rev 1: 21st August 2011

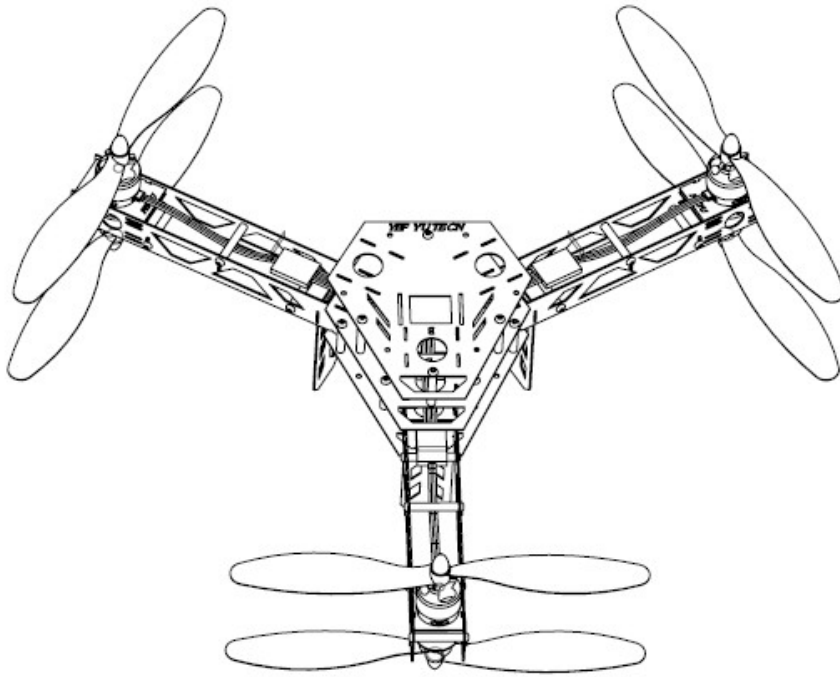

**FEIYU
TECH**

Y6 SCORPION FLYER

Multi-rotor Aircraft build Manual



Guilin Feiyu Electronic Technology Co., Ltd

Rm. B305, Innovation Building, Information Industry Park, Chaoyang Road, Qixing District,
GuiLin, CN

www.feiyu-tech.com

Email: feiyutech@yahoo.cn

Aircraft Parameters

1. Dimensions

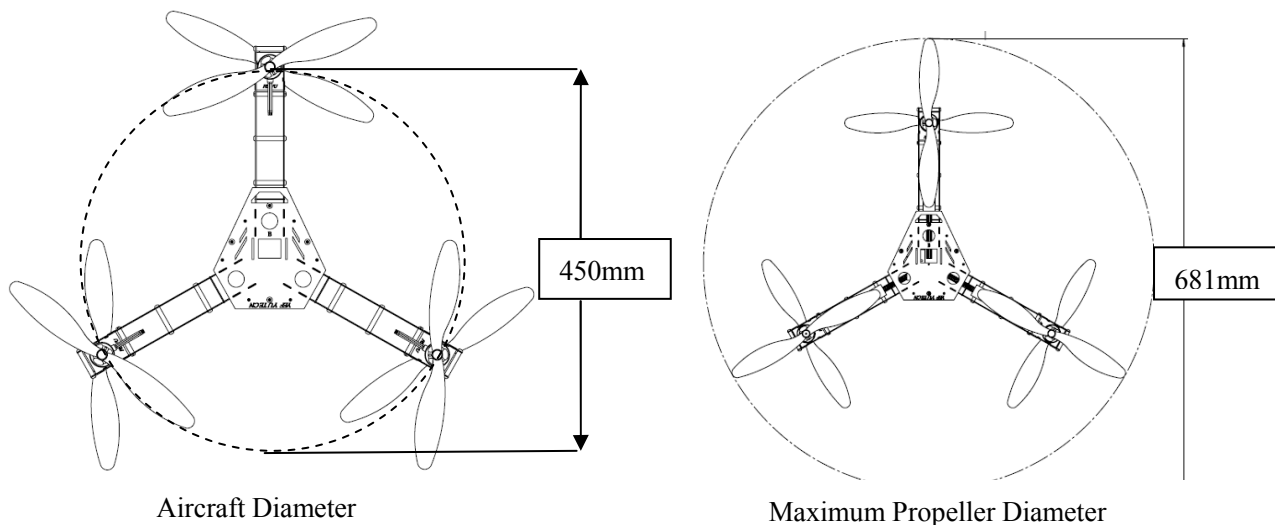

2. Empty Weight: 630g (receiver and battery not included)
3. Payload capacity: 800g (includes battery, receiver, etc.)
4. Maximum Gross Take-Off Weight: 1430 grams. For safety reasons do not exceed this weight.
5. Airborne time (with 3S 2200mAh Lipo battery) : Approximately 10 minutes
6. Power requirement: 3S1P Lipo, 1500 to 5000mAh, Discharge rate: 15C and above.
7. FY-ESC (included): 10A (a standard PWM ESC).
8. Suitable for FY91Q Flight Controller.
9. Require at least a 5 channel RC Receiver.

Note: Please always consider safety first when using this model aircraft. Take all required precautions to prevent accidental injury:

- Do Not Fly over people.
- Do Not use as a chase copter.

Installation Tools

1. Soldering Iron
2. Good solder with Rosen core
3. 2.0 mm Allen wrench (provided)
4. 2.0 mm diameter screwdriver

Step 1: Frame Arm Assembly (3 sets)

1. Unpack the Arm pairs. Note the arms have LEDs with color: Blue, Red or Green.
2. Unpack these parts to complete the 3 arm sets:
 - M3 x 5mm button head screws & M3 x 30mm pillars
 - six motor mount plates
 - six motors.
 - six landing gears.

Figure 1: Arm set installation. Ensure the LED lights are facing outwards:

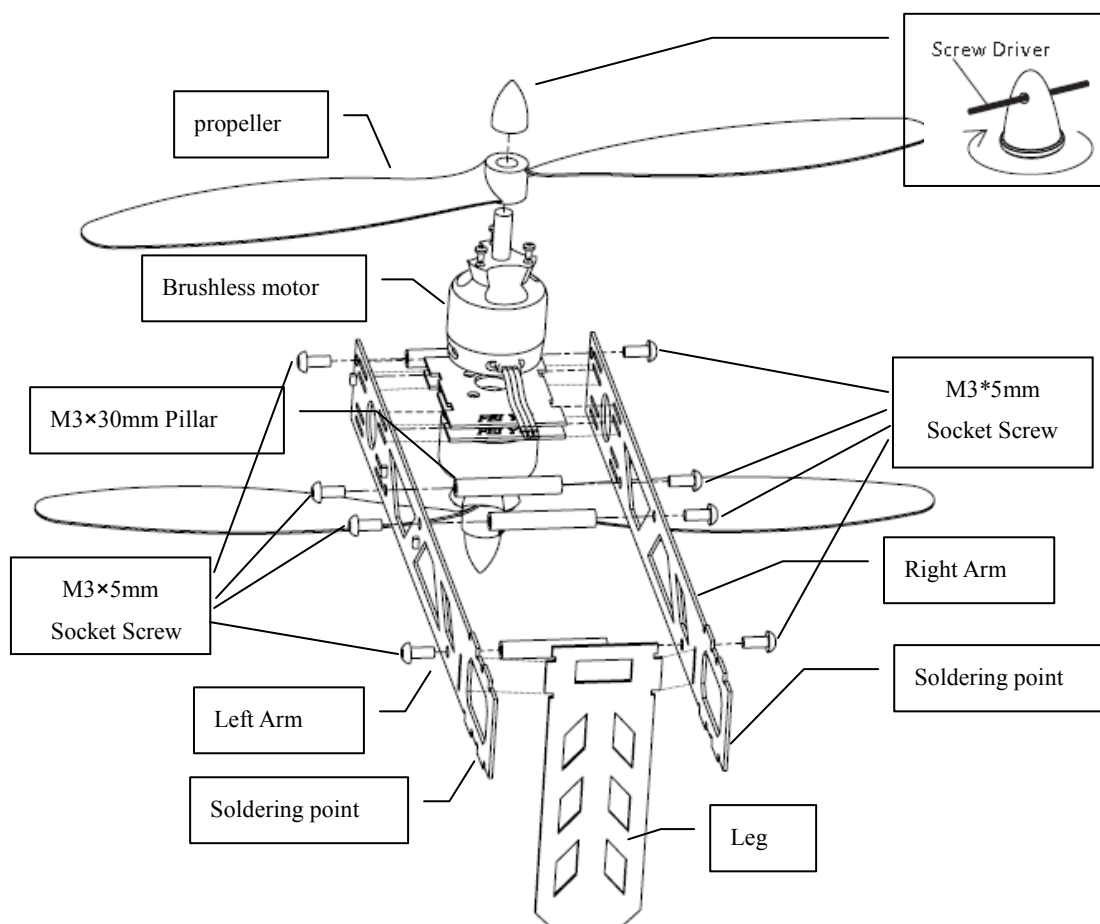

Note: When assembled properly, the “Feiyu Tech” words should be facing upright and the welding points lined up perfectly.

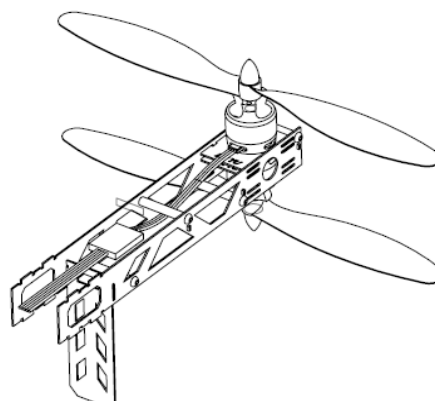
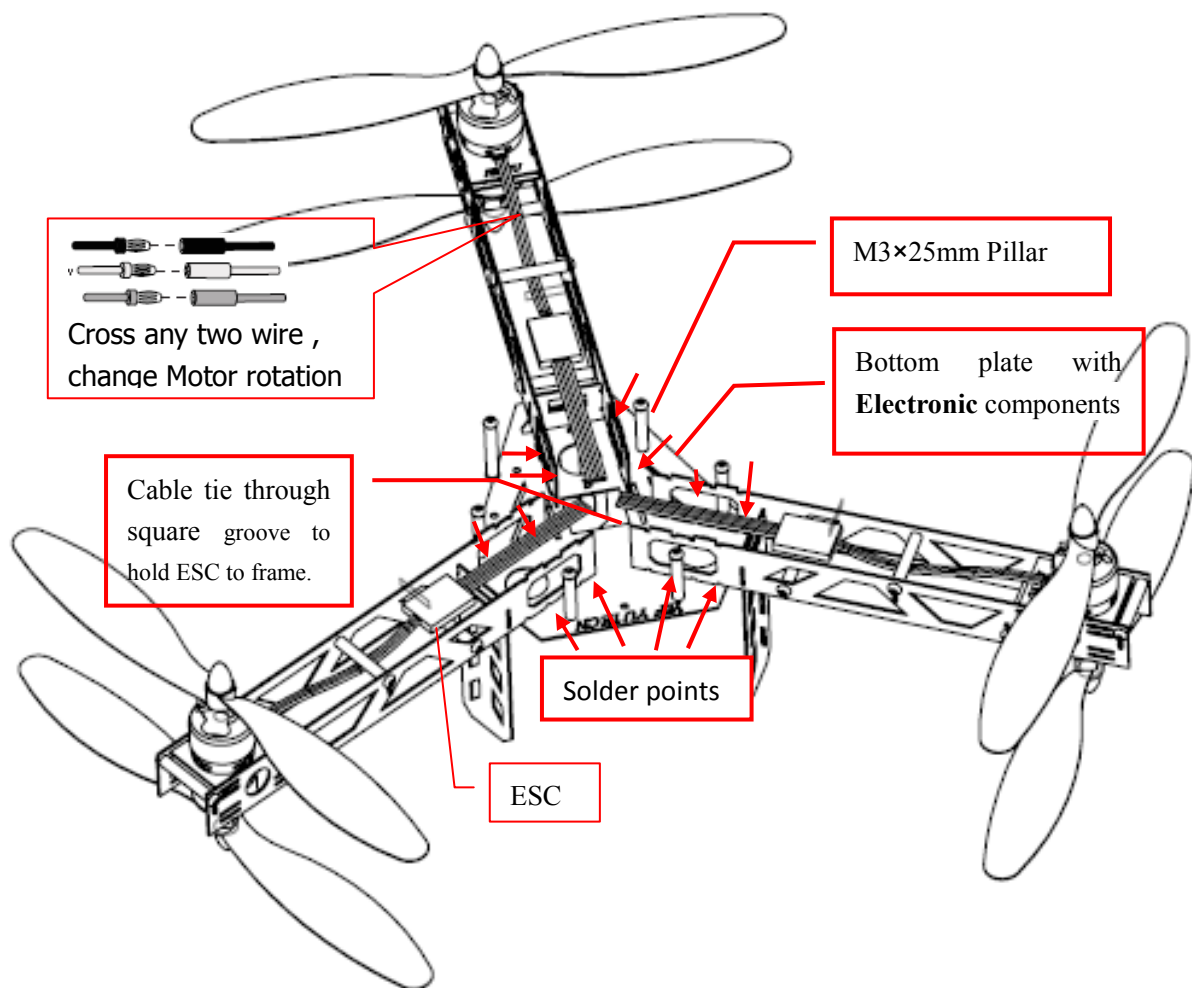

Figure 2: Solder (red arrows) the 3 arms onto the bottom fuselage plate:



1. Proceed with installing the 3 arm sets as shown above.
2. **Caution:** Do not overheat the arm contact points, as the metal will deform making it difficult for arm insertion into the fuselage plate.
3. To check LED light function, connect a 3S Lipo balance plug to the socket at the bottom of the fuselage; the LEDs will light up. You may also check with a DC meter at the solder point; it should indicate approximately 2.3 Volts.

Step 3: Install ESCs and flight pack Power connector

1. After soldering the 3 arms, install the 6 ESCs by connecting the 3 ESC output wires to the 6 motors. At this juncture, don't worry about the motor rotation direction.
2. Run both the ESC servo lead and power supply to the middle fuselage. Connect the power input leads to the JST connectors and exit the T-Plug as shown below.
3. After completing ESC install, you may proceed with the middle plate installation. Don't forget to pull the 6 servo leads from the ESCs through the middle plate for later connection to the FY91Q.
4. After installing the middle plate, you can proceed to install the flight controller (FY91Q) via the damper mount / anti-vibration pads.
5. Install your RC Receiver and complete the connection with the FC as per the FC's manual.

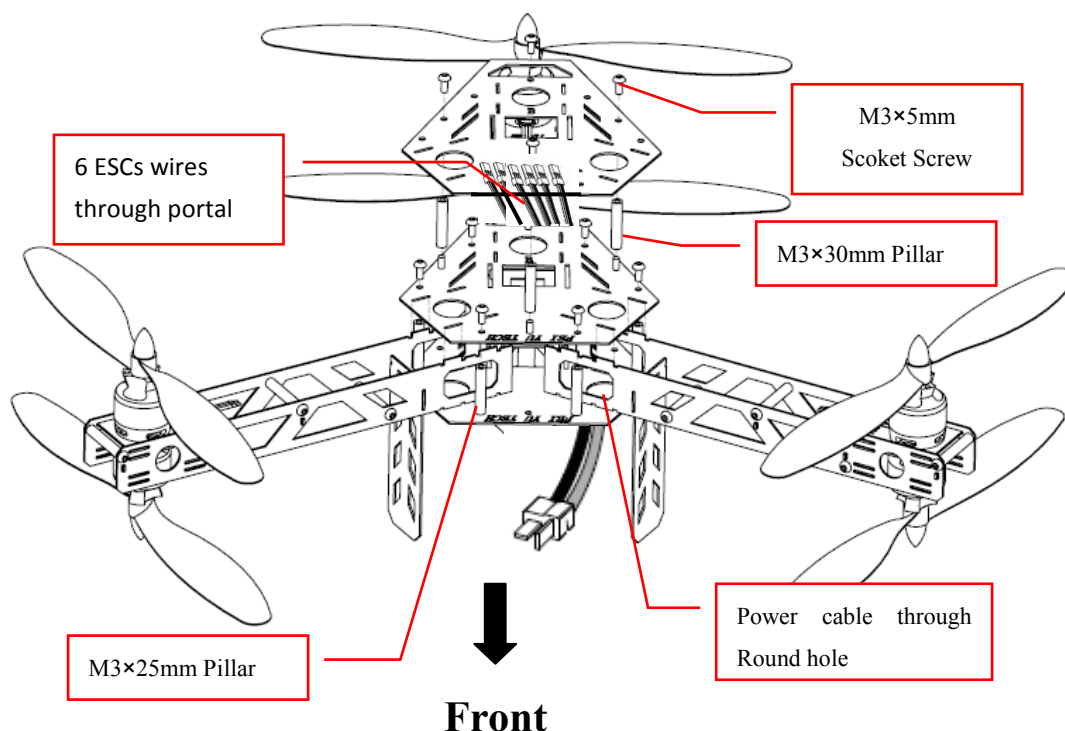

Step 4 : Test The Motor Rotation

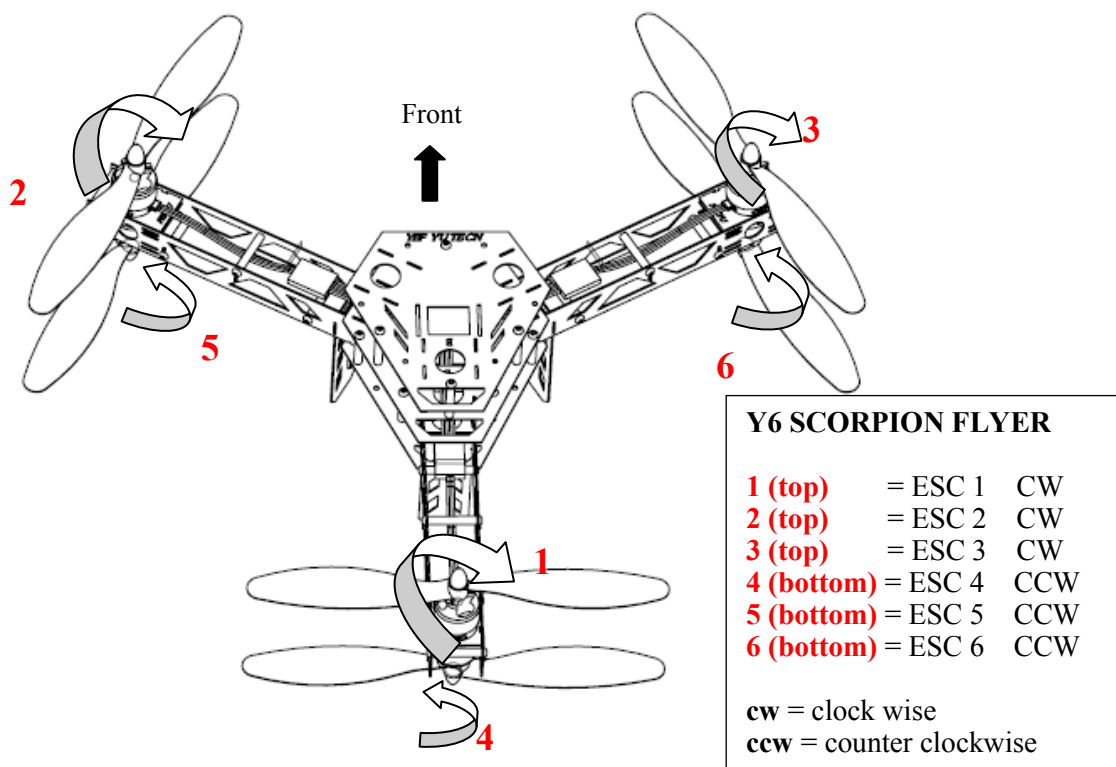

1. After installing the FC, activate the quad and carefully check that the propeller rotation is as shown above.
2. If any of the motors are rotating in the opposite direction to what is noted above, change any two wires of the ESC 3 wire motor plug. This will correct the propeller rotation.
3. Lastly install the top fuselage plate to protect the FC and RC Receiver.

Step 5: Voltage Level Indication via Fuselage LED Flashing

1. When flying, the white LED on the bottom plate will begin flashing to indicate the voltage of your flight battery, as follows:

					Battery Voltage			
					>11.5V	11.1V~11.5V	10.8V~11.1V	<10.8V
LED Flash	SOLID	Slow flash	Medium flash	Fast flash				
Indication	Enough power	Voltage down	Land now	Emergency Landing				