

Rev 6: 7<sup>th</sup> July 2011

**FEIYU**  
**TECH**

# **FY-91Q DREAMCATCHER**

Multi-rotor flight stabilization & Autopilot System  
Installation & Operation Guide



**Guilin Feiyu Electronic Technology Co., Ltd**

Rm. B305, Innovation Building, Information Industry Park, Chaoyang Road, Qixing District,  
GuiLin, CN

[www.feiyu-tech.com](http://www.feiyu-tech.com)

Email: [feiyutech@yahoo.cn](mailto:feiyutech@yahoo.cn)

## Table of Contents

FY91Q MULTI ROTOR SYSTEM Basics on how the system works: .....	3
Barometer and GPS & COMPASS module .....	3
Autopilot Function .....	4
Auto Hover .....	4
Automated Return to Home .....	4
ON SCREEN DISPLAY and DATA RADIO .....	4
FY91Q Navigation Edition Package Content .....	5
SYSTEM SPECIFICATIONS .....	5
FY-91Q FLIGHT MODES .....	7
Flight Modes and LED Indicator .....	8
GPS Status & Vibration LED Indicator .....	8
GPS & COMPASS Module Interface & Function .....	9
GYRO RESETTING .....	10
FY91Q Connection Interface Diagram .....	11
DIP SWITCH SETTING .....	12
FY-91Q Power Supply Recommendations .....	13
FY91Q Connection to the Receiver .....	13
VIBRATION DAMPING .....	14
CHECKING FOR VIBRATION .....	15
QUADCOPTER SET UP .....	16
Y6 FY91Q CONNECTION SCHEMATICS .....	18
FY91Q Module Installation .....	20
FY91Q Preflight Inspection and Initial Testing .....	20
SETTING UP HOVER HOLD AND AUTOMATIC RETURN TO HOME .....	22
1 <sup>ST</sup> PRINCIPLE: HOVER USING YOUR TRANSMITTER TRIMS .....	22
2 <sup>ND</sup> PRINCIPLE: THE FLIGHT NEUTRAL GAIN .....	23
3 <sup>rd</sup> Principle: FY91Q LEARNS ON-THE-FLY FOR HOVER HOLD .....	25
4 <sup>th</sup> Principle: THROTTLE IS THE KEY .....	26
iii) GPS DETECTION (HOME LOCK) .....	28
HOVER HOLD AND AUTOMATIC RETURN TO HOME TESTING .....	29
FLIGHT PARAMETER ADJUSTMENT SOFTWARE .....	30
FY91Q Ground Control Station Function .....	35
FY91Q Connection to AP117 ON SCREEN DISPLAY .....	37
UPGRADING THE FY91Q FIRMWARE .....	38
FY91Q / FY90Q BASIC SYSTEM REQUIREMENTS .....	39
Electronic Speed Control (ESC) Requirements: .....	39
Pre-Flight Check & Sensitivity (Exponential) Adjustments .....	39
ESCs Not Arming .....	41

**Dear Pilot,**

Thank you for purchasing the FY91Q multirotor flight control system from Feiyu Tech.

In order to achieve full potential and safe operation of this product, please carefully read this manual prior to installation.

**ATTENTION:**

- Set up and use of the FY91Q requires a high degree of multi-rotor flight and RC experience.
- If you have never flown a multi rotor aircraft before, we highly recommend that you don't install this equipment on your own. Please seek assistance from an experienced multirotor pilot.
- If you are already an experienced multirotor pilot, you will find the installation mildly challenging but logical. Just follow the instructions as stated in this manual and you won't go wrong.
- Remember, *SAFETY ALWAYS FIRST.*

If you need any technical support you know where to find us.

## **FY91Q MULTI ROTOR SYSTEM**

### **Basics on how the system works:**

- **Inertial Stabilizer:** The FY91Q utilizes an attitude flight stabilization system (AFSS) which is inertial sensing based. The system also incorporates an autonomous flight control system.
- The FY91Q AFSS integrates a three-axis gyroscope combined with tri-axial accelerometers to sense and create a drift-free 3 dimensional stabilization system.
- The FY91Q also utilizes GPS and barometric pressure sensing to obtain accurate aircraft positioning and altitude.
- By combining sensor data from the gyros and accelerometers, together with altitude and GPS positioning, an accurate inertial navigation and autopilot system is formed. Fixed positioned and altitude hover and return to home is just a switch away.
- This product is still under intense Research and Development. FeiYu Tech has enabled firmware upgrading via a USB-TTL Connector. As new algorithms are developed for the autopilot system, you can download the upgraded firmware from FY website.

### **Barometer and GPS & COMPASS module**

- ❖ FY-91Q control module incorporates an accurate barometric pressure sensor. At start up, the take-off air pressure is measured, providing the autopilot with an accurate relative height data.
- ❖ The GPS & COMPASS module provided with the FY91Q Navigation Edition consist of a three-axis magnetic sensor and high sensitivity GPS receiver. This module enables the autopilot to sense the flight course and exact location of the aircraft.
- ❖ Note that if the FY91Q is not connected GPS & COMPASS module, it will function as purely as a flight stabilizer for multi rotor aircraft. The autonomous flight system cannot be engaged.
- ❖ For the autopilot to function, the GPS Receiver must detect at least 5 satellites.

## **Autopilot Function**

The current FY91Q firmware supports two autopilot functions; fixed altitude Auto Hover and automated Return to Home. To enable autonomous flight, the GPS & Compass module must be connected to the FY91Q:



### **Auto Hover**

- 3 dimensional GPS positioning is used to automatically maintain aircraft hover position and altitude.
- Accuracy of hover position (range) depends on wind conditions and speed.

### **Automated Return to Home**

- By utilizing GPS positioning, the autopilot will return the aircraft to the starting point upon activation of the RTH Mode.
- Upon reaching the starting point (home) the autopilot will activate Hover Hold, maintaining position and altitude while waiting for your further instructions.
- To establish the Home point, a minimum of 5 GPS satellites must be detected.

## **ON SCREEN DISPLAY and DATA RADIO**

- a. The FY91Q supports OSD data output via the UART interface.
- b. By connecting this interface to the AP117 OSD, telemetric data such as GPS, flight navigation, AHI, and autopilot modes can be displayed on your downlink video.
- c. The UART Interface can also be connected to the FY-606 digital data radio system, which establishes a bi-direction radio communication between the FY91Q and your portable computer.
- d. By uploading our Ground Control Software (GCS) (free from our website), you can monitor your flight on the GCS map, display on-board telemetry data and control the aircraft flight path via the click of your mouse.

## **FY91Q Navigation Edition Package Content**

FY-91Q Navigation Edition contains the following hardware:

- FY-91Q control module x 1;
- FY91Q RC receiver connection cable pack x 1;
- GPS & COMPASS Interface module x 1;
- FY GPS Receiver x 1
- Double-sided adhesive Damper pad x 1;
- Self-adhesive Velcro sponge x 2;
- GPS connecting wires x 1
- Jumper for gyro resetting x 1

## **SYSTEM SPECIFICATIONS**

### **FY-91Q Module**

Operating voltage	: 4.0~6.0 Volt
Current consumption	: 50mA (5V input)
Dimensions	: 55 x 33 x 20 mm
Weight (not including wires)	: 20g
Operating Temperature	: -25°C~ +70°C
The maximum allowable rotation rate	: 3 rotations per minute

### **GPS & COMPASS INTERFACE MODULE**

Operating voltage	: 4.0~6.0 Volt
Current consumption	: 60mA (5V input)
Dimensions	: 55 x 33 x 20 mm
Weight (not including wire)	: 20g
Temperature range	: -25°C~ +70°C

## **APPLICABLE AIRCRAFT MODELS**

The FY91Q can be installed and flown in the following multi-rotor aircraft:

- ❖ 4 motored Quadcopters;
- ❖ Tri-axial rotary aircraft with 6 motors (Y6)
- ❖ Tri-axial rotary aircraft with 4 motors (Y4)
- ❖ Six-axial multi-rotor aircraft (Hexacopters)

Any other configuration, please contact us for confirmation: feiyudz@hotmail.com

## **REMOTE CONTROL SYSTEM COMPATIBILITY**

FY-91Q have been tested to work with the following RC systems:

- Robbe-Futaba PPM / PCM 1024 / PCM G3 mode, 2.4 GHz systems ;
- Graupner/JR PPM 8, PPM 12, SPCM mode ;
- MPX PPM8, PPM 12 with UNI mode
- Any remote control system using the standard of 1.5 ms *neutral position*.

## FY-91Q FLIGHT MODES

1. FY-91Q has three operating Flight Modes, which is selected by using any free channel on your RC receiver.
2. You can set the 3 modes via a 3 way switch or use a dial knob. Example:

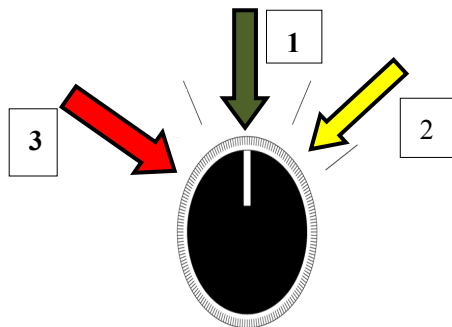

3. However, since switch flight modes is required during the setting for autonomous flight, **we highly recommend that you use the 3-way switch.**

Receiver PPM signal level	900-1200µs	1200-1800µs	1800-2100µs
FLIGHT MODES	<b>Mode 3:</b> Return to Home	<b>Mode 1:</b> Stabilizer Mode	<b>Mode 2:</b> Automated Hover Hold

### **Mode 1:** *Stabilized Mode*

In this mode, the FY-91Q will stabilize the multi-rotor aircraft for normal flight. Full flight direction control is given to the pilot.

### **Mode 2:** *Automated Hover Hold.*

In Hover Hold, the aircraft will maintain hover altitude and position. The GPS and Compass Module must be connected to the FY91Q with at least 5 GPS satellites detected.

### **Mode 3:** *Automated Return to Home Mode.*

Activating this mode will automatically initiate the aircraft to fly back to the Home point. Requires the GPS and Compass Module to be connected to the FY91Q with at least 5 GPS satellites detected.

### Flight Modes and LED Indicator

- To indicate the flight modes of the FY91Q, the Blue LED light will flash:



Flight Modes	Mode 1 <i>(Stabilized Mode)</i>	Mode 2 <i>(Hover Hold)</i>	Mode 3 <i>(RTH Mode)</i>
<b>Blue LED Flashing</b>	LED Always On	Continuous flashing	Three intermittent flashing

### GPS Status & Vibration LED Indicator

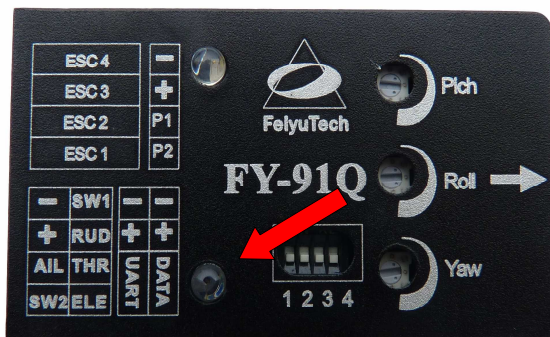

The GPS connection status & vibration level is indicated by the Red LED Flashing:

<b>GPS &amp; Vibration Status</b>	Severe vibration*	GPS & COMPASS module not connected	5 GPS Satellite detected (Home position Locked)
<b>Red LED flashing</b>	Continuous flashing	None (LED light OFF)	Double Intermittent Flashing

\* In case severe vibration is detected reduce your aircraft vibration levels or improve vibration damping for the FY91Q mounting.

## GPS & COMPASS Module Interface & Function

1. To enable the autopilot options you must have the GPS & COMPASS module connected to the FY-91Q.

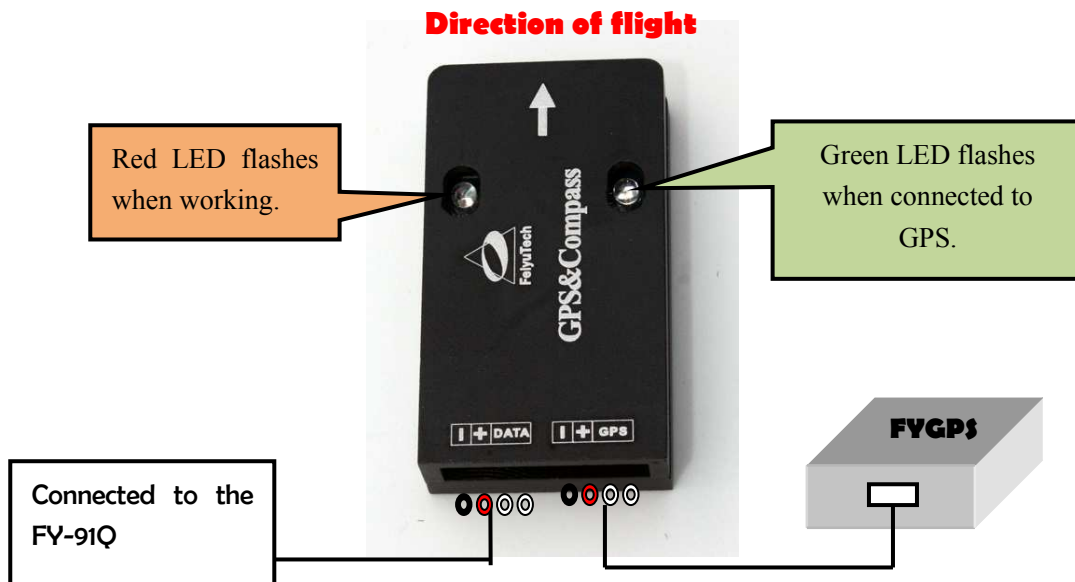

2. **IMPORTANT:** The GPS & COMPASS Module is sensitive to vibration. Please use the included damper sponge when mounting this module.
3. **WARNING:** Wrong installation of the GPS & COMPASS Module will result in inconsistent performance and even autopilot malfunction.
4. GPS & COMPASS module is utilizes a ceramic passive GPS Receiver. This FY-GPS Receiver must be installed face up as indicated on the sticker.
5. Do not allow any metal or carbon fiber material to block or shield the FY-GPS from detecting GPS satellite signal.
6. **WARNING:** The GPS & COMPASS Module is very sensitive to metal, magnets, electromagnetic fields and radiation. Keep such materials as far away from the Module as possible. Example: main power cables, servo and servo wires, video transmitters, ESCs, motors, etc. all can affect the GPS & Compass Module.



## **GYRO RESETTING**

1. Out of the box, the FY-91Q has already been initialized and is ready to use.
2. Generally the FY91Q gyros do not need to be re-set, but under certain conditions initializing the gyros does become necessary:
  - a) The unit has not be used for a long time,
  - b) Extreme change in environmental temperature in excess of 30°F.
  - c) FY91Q fails to start the motors
  - d) The blue light of the FY91Q is blinking continuouslyIf any of the above has occurred, please proceed with the initialization process.
3. Note that routine gyro resetting is not necessary.

### **4. Gyro Re;etting Process**

- a. The FY91Q does not have to be leveled, however please ensure it is not moved, shaken or experience any kind of vibration during the initialization process. If movement / vibration did occur, please repeat the procedure.
- b. Install the gyro initialization jumper as shown below:

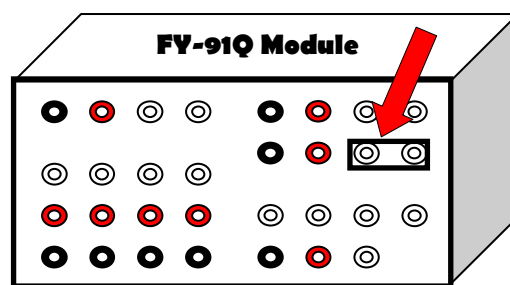

- c. Supply power to the module and ensure it remains stationary for at least 20 seconds.
- d. The red LED light will flash in two different rates.
- e. After approximately 20 seconds, the initialization process is complete.
- f. Disconnect the power supply and unplug the jumper (please keep in a safe place for future use).

### FY91Q Connection Interface Diagram

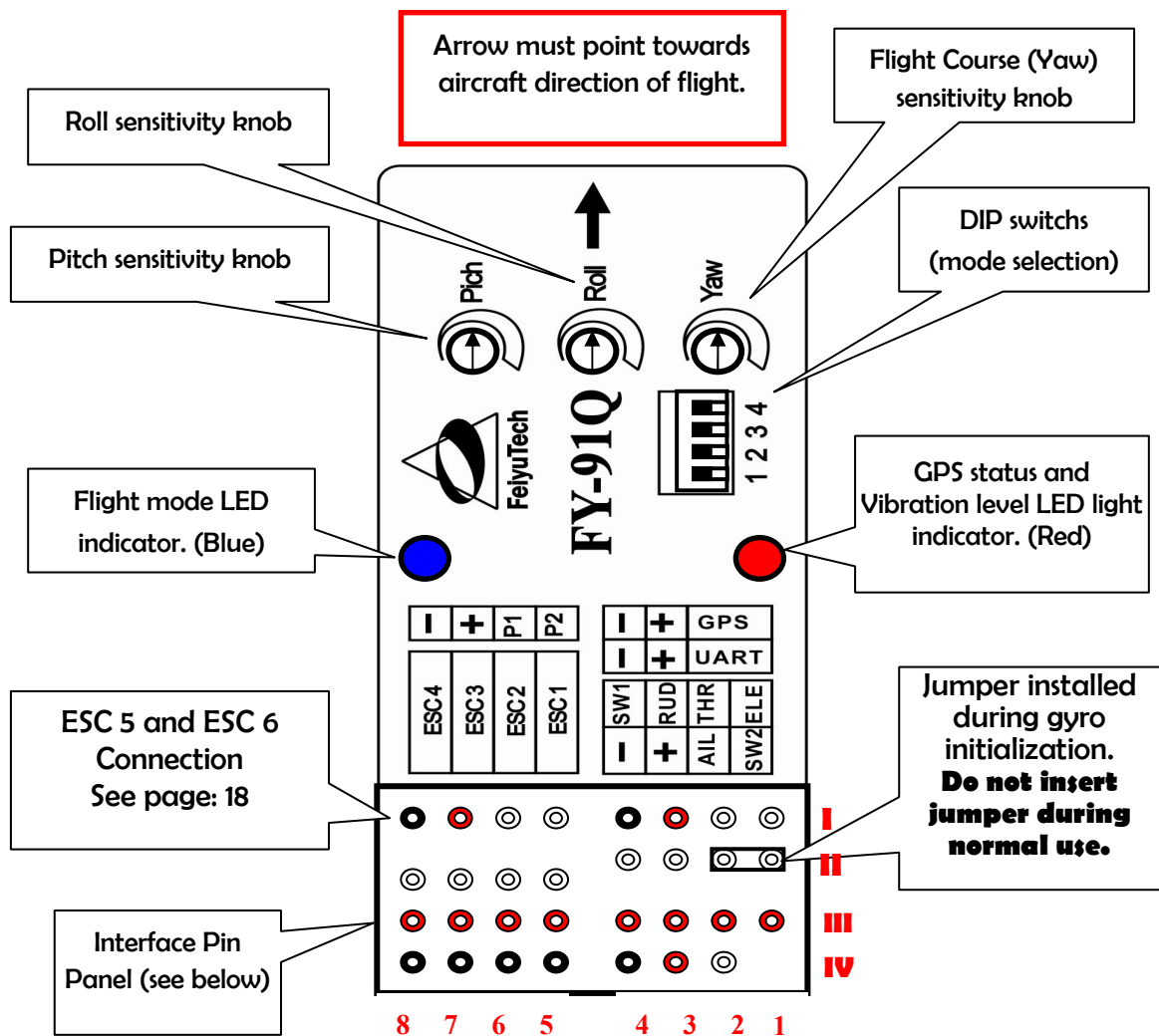

#### Interface Pin Panel Connection:

8	7	6	5	4	3	2	1	
GND	Null*	P1	P2	GND	Power	TX0	RX0	I
ESC4	ESC3	ESC2	ESC1	GND	Power	TX1	TX1	II
Null*	Null*	Null*	Power Input	Rx free channel (Switch 1)	Rx Rud (Ch 4)	Rx Throttle (Ch 3)	Rx Ele (Ch 2)	III
GND	GND	GND	GND	GND	Power	Rx ALL (Ch 1)	No Pin	IV

Null\* : Do not connect anything on these pins (leave open).

### DIP SWITCH SETTING

The FY91Q utilizes a Dip Switch system for model selection, via Dip switch No. 2 to 4:

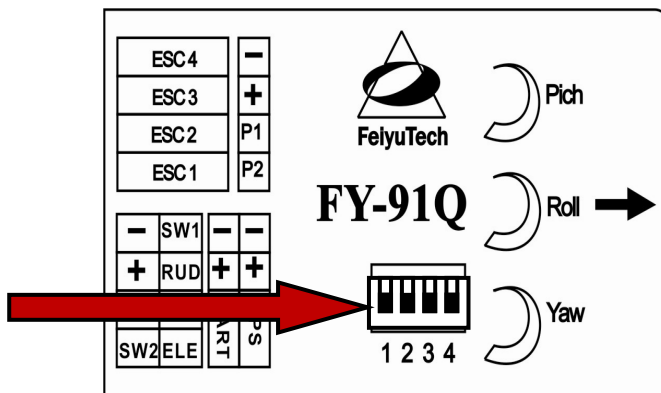

Switch Position	1	2	3	4
<b>ON</b>	(Factory use only)	Flight mode debugging	X-format	Y6 flight mode
<b>OFF</b>	Always OFF	Normal flight mode	Cross format	X4 flight mode

**Switch Diagram Reference:** the switches below are in the **OFF POSITION:**

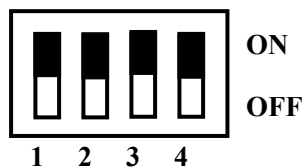
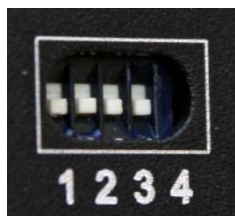

**Example:**

a. Dip Switch position for X-TYPE QUADCOPTER:

- 1 = OFF
- 2 = OFF
- 3 = ON
- 4 = OFF

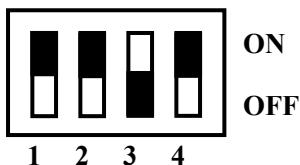

b. Dip Switch position for CROSS-TYPE QUADCOPTER:

- 1 = OFF
- 2 = OFF
- 3 = OFF
- 4 = OFF

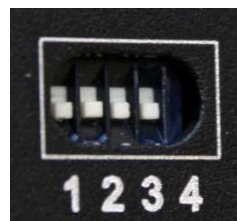

c. Dip Switch position for CROSS-TYPE Y6:

- 1 = OFF
- 2 = OFF
- 3 = OFF
- 4 = ON

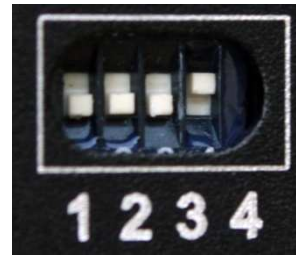
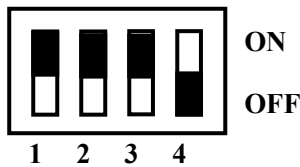

d. Dip Switch position for Hexa-Copter:

- 1 = OFF
- 2 = OFF
- 3 = OFF
- 4 = ON

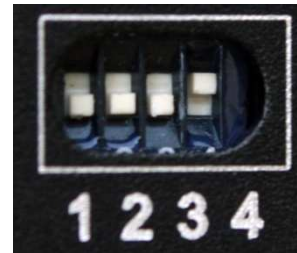
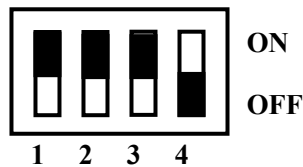

**FY-91Q Power Supply Recommendations**

1. The FY91Q input power supply can range from 4 to 6 volts.
2. More importantly, the current input and voltage must be stable.  
You may use an external BEC with 3A output or use ESC with good quality 3A BEC.
3. We recommend that power is supplied via the ESC 1 power input pin
4. Your radio receiver power supply is via the FY91Q Aileron cable (channel 1).

**FY91Q Connection to the Receiver**

1. The FY91Q is connected to the receiver via this cable bundle:



2. The wire colors will help you trace the connection to your Receiver:

<b>Wire Colour</b>	<b>Receive Channel</b>	
White (bundled with red and black)	Aileron	Channel 1
Orange	Elevator	Channel 2
Green	Throttle	Channel 3
Yellow	Rudder	Channel 4
Brown	Any free channel controlled by 3-way switch or dial (refer page 6)	Channel 5 (example)

3. Note that the open channel for Switch 1 (SW 1) must be controlled by either a 3-way switch or a dial on your radio transmitter. SW1 controls the Flight Modes of the FY91Q.

**VIBRATION DAMPING**

- a) The FY91Q flight controller algorithms can filter and operate under normal vibration levels, however if the vibration and shock experienced by the onboard sensors is too extreme, stabilization can fail and the system can shut down altogether.
- b) Because of this, to achieve the best stabilization and flight performance out of the FY91Q, you must minimize the amount of vibration on the aircraft as best you can.
- c) Examples of vibration reduction steps that can be taken:
  - i) Ensure your motors are mounted properly and squarely.
  - ii) Balance your propellers regardless of the manufacturer’s claim of perfect balance out of the factory.
  - iii) Balance your motor bell housing (if possible).
  - iv) Ensure rigidity of your frame (will not flex with motor rotation).
  - v) Use appropriate propeller length and pitch for the weight of your aircraft.

- d) The FY-91Q is supplied with the shock absorbing mount and double-sided foam padding dampers. Please use them as shown below:



### CHECKING FOR VIBRATION

- a) Install the FY91Q as per the recommendations of this manual, including directions of propeller rotation.
- b) Remove the connection to the GPS & Compass Module.
- c) Throttle up in Mode 1 (*Stabilized Mode*) but **do not take off!**



- d) Observe the red LED on the FY91Q module.
- e) If the red LED light remains OFF, this indicates your aircraft vibration level is acceptable.
- f) If instead the red LED light goes ON and remains lighted, your aircraft does not meet the vibration level requirement. Please reduce the onboard vibration level.

## QUADCOPTER SET UP

### X-Type Layout

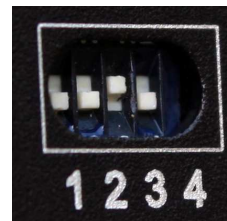
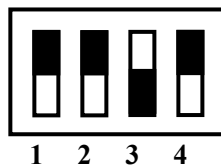
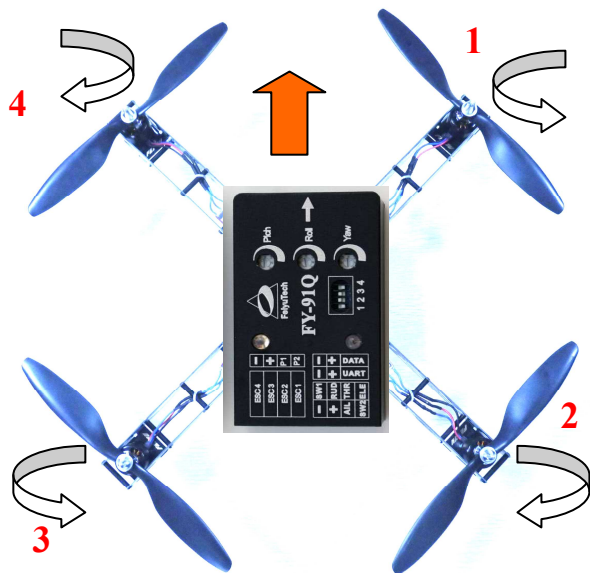

*X-Type QuadCopter Layout:*

- 1** = ESC 1 CCW
- 2** = ESC 2 CW
- 3** = ESC 3 CCW
- 4** = ESC 4 CW

**cw** = clock wise  
**ccw** = counter clockwise

### Cross Type Layout

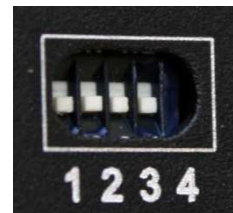
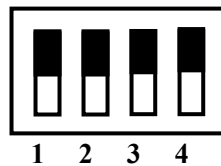
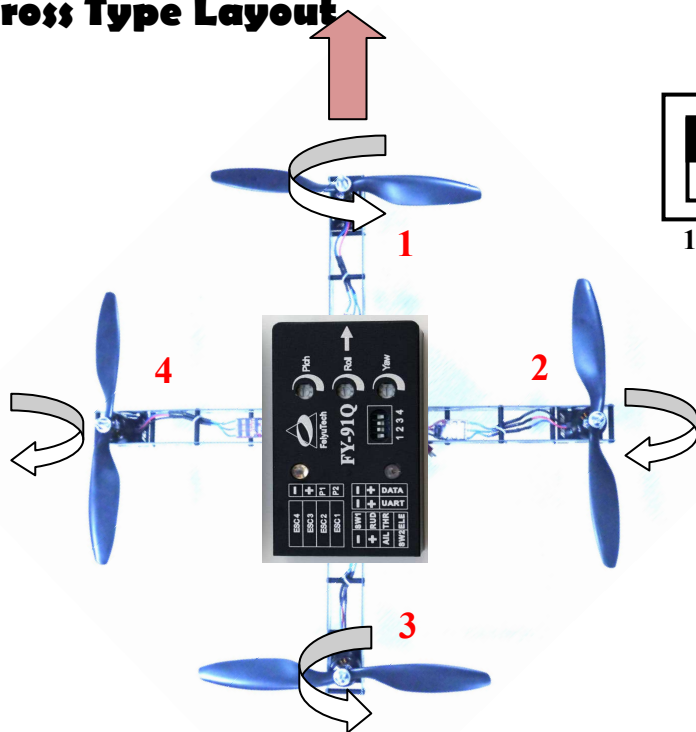

**+** - Type Quad Layout:

- 1** = ESC 1 CCW
- 2** = ESC 2 CW
- 3** = ESC 3 CCW
- 4** = ESC 4 CW

**cw** = clock wise  
**ccw** = counter clockwise

### QUADCOPTER FY91Q CONNECTION SCHEMATIC

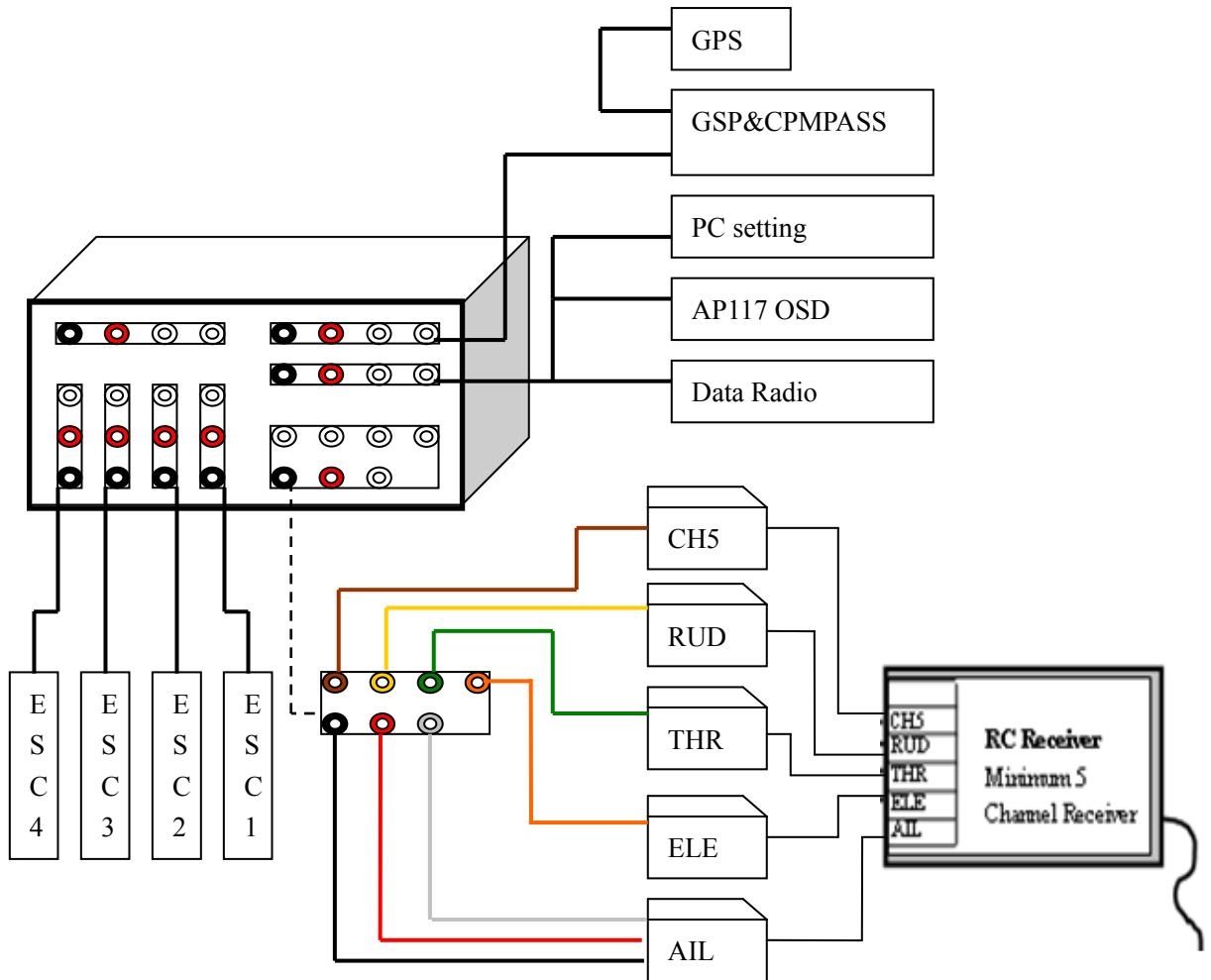

### Y6 FY91Q CONNECTION SCHEMATICS

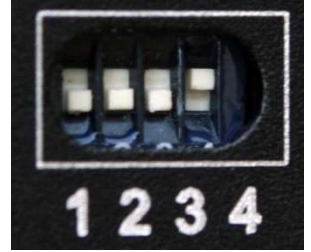
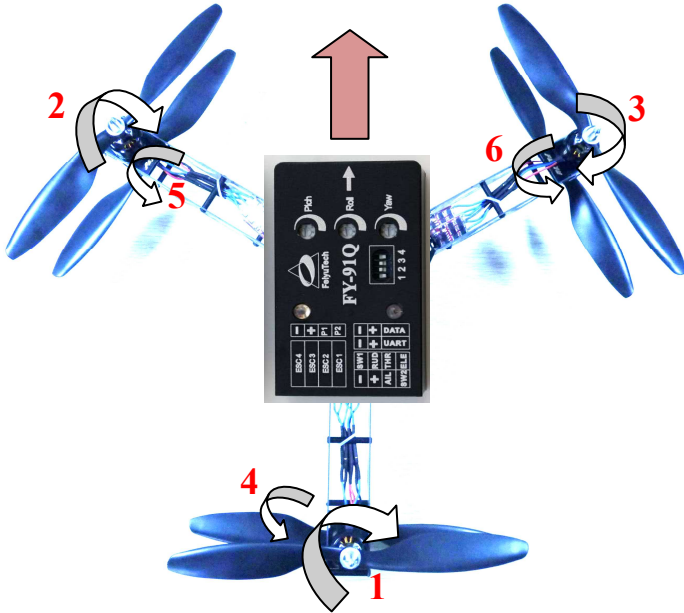

#### Y6 SCORPION FLYER

- 1 (top)** = ESC 1 CW
- 2 (top)** = ESC 2 CW
- 3 (top)** = ESC 3 CW
- 4 (bottom)** = ESC 4 CCW
- 5 (bottom)** = ESC 5 CCW
- 6 (bottom)** = ESC 6 CCW

**cw** = clock wise  
**ccw** = counter clockwise

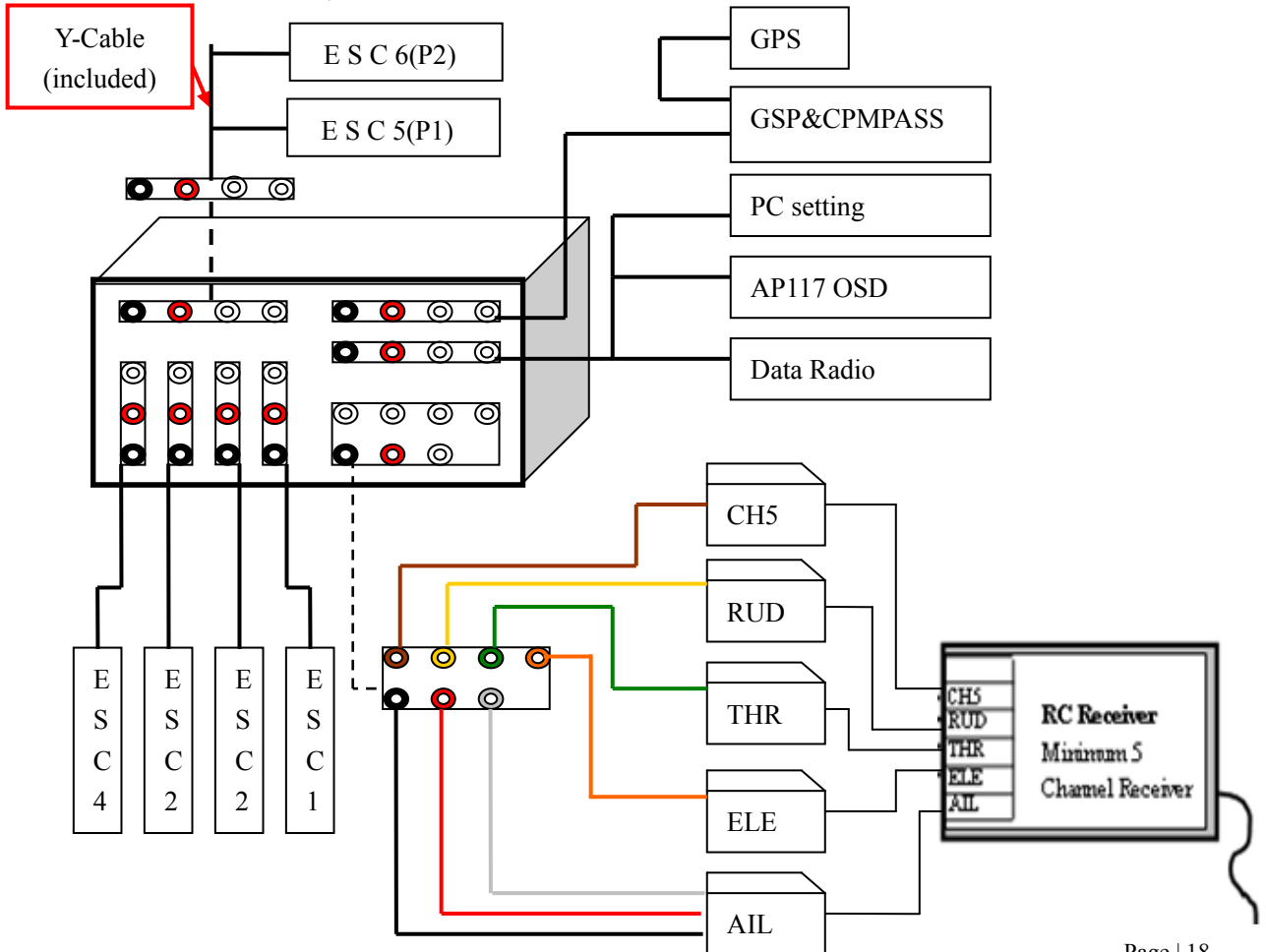

### FY91Q Hexa Copter Setup

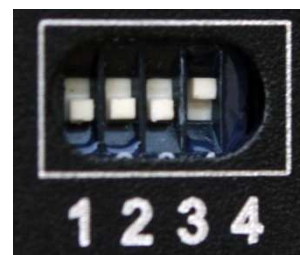
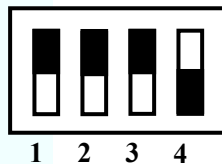
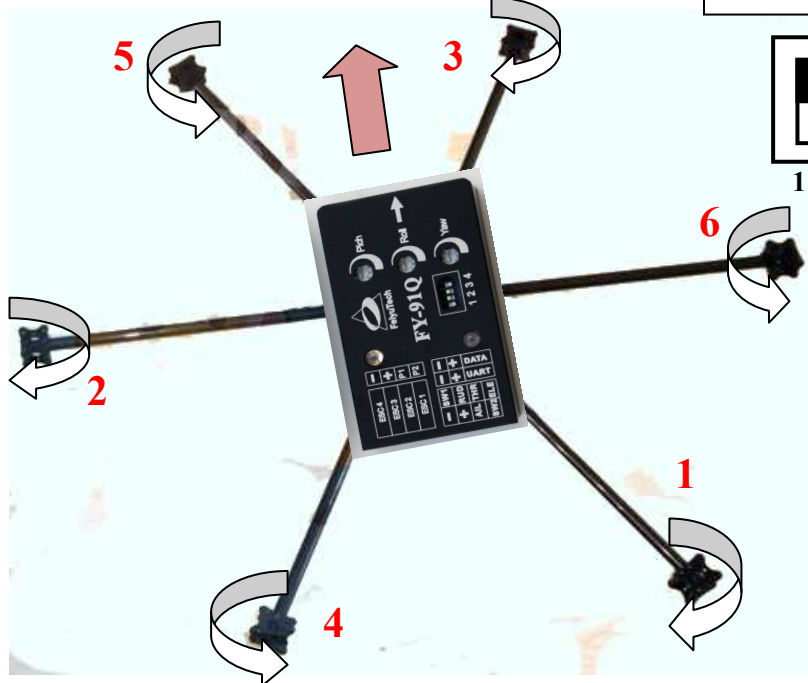
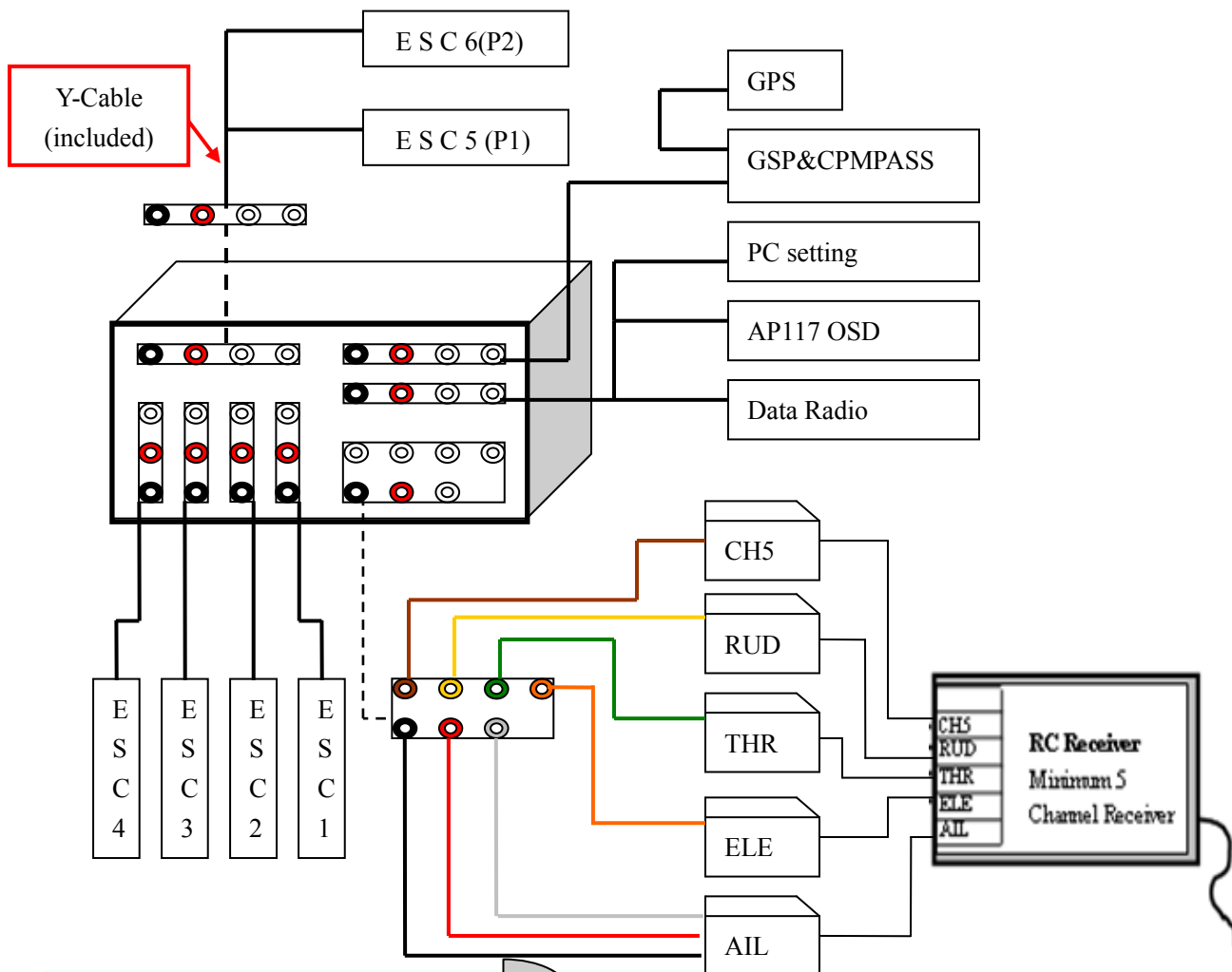

**X - Type Hexa Layout:**

- 1 = ESC 1 CW
- 2 = ESC 2 CW
- 3 = ESC 3 CW
- 4 = ESC 4 CCW
- 5 = ESC 5 CCW
- 6 = ESC 6 CCW

CW = clock wise  
CCW = counter clockwise

**Direction of flight**

## **FY91Q Module Installation**

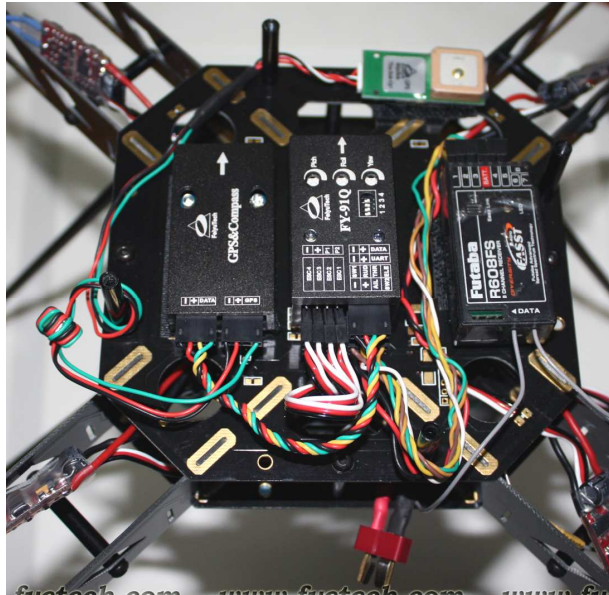

1. FY91Q has an arrow indicator on top. Please ensure this arrow is pointed towards the direction of flight.
2. Installed the module horizontally, and as close as possible to the aircraft center. A more centered installation will result in more stable drift free hover.
3. The FY91Q sets its own benchmark of what is 'horizontal'. Install the module based on the hover characteristics of the aircraft in Mode 1 (Stabilized Mode). Shimming the module may be required to get the aircraft to hover perfectly.

## **FY91Q Preflight Inspection and Initial Testing**

Pre-flight testing for aircraft control:

1. Remove all propellers.
2. Activate throttle to start up the motors. Check the rotation direction of each motor and make sure it is turning in the right direction.
3. Re-Install propellers.
4. Check again that the rotation is correct.
5. Check the FY91Q sensitivity control knobs. Please ensure the dials are beyond 12 o'clock. Anything less than that may result in no flight stability for this first flight.

6. **Tie down test:** Before proceeding, we highly advise that you tie down the aircraft to the ground to prevent any possibility it going out of control during this initial flight tests. Safety first.
7. **First test lift off:** Advance your throttle stick, but do not take off (usually around 30% throttle). Let the aircraft float just enough so that you can see the aircraft reaction as you move your Aileron, Elevator and Rudder sticks.
8. If the control movement is reversed, just reverse the channel on your RC transmitter.
9. After step 8, you can take off higher. If the aircraft hovers well, you can proceed to remove the aircraft from the tie down test.
10. Observe the flight for stability and oscillations as the aircraft hovers higher.
11. If you feel there is not enough stability (e.g. excessive drifting), you can increase the sensitivity of the three dials.
12. If there are rapid oscillations, reduce the corresponding sensitivity knob.
13. More fine tuning adjustment can be done via the FeiYu software (you will need the TTL-USB cable for this).

### **Pre-flight Debugging**

1. If your aircraft fails to lift off and hover for the initial pre-flight tests, please check the following:
  - a) Check the ESC connections are all correctly plugged in. Take time to check and re-check that each ESC has been plugged in and that the plugs are correctly placed.
  - b) Please ensure there is no short circuit of the power (positive) and GND wires. Short circuits can damage the internal processor chip beyond repair (voiding all warranty).
  - c) Check that all motors are rotating in the direction noted in this manual.
  - d) Ensure you have selected mid or high timing for your ESC (if you are not using FY ESCs).

## SETTING UP HOVER HOLD AND AUTOMATIC RETURN TO HOME

- a) Note: commissioning the Hover Hold and RTH Mode require a certain degree of flying skill. You may need a friend's assistance to carry out the entire procedure.
- b) Setting up involves:
  - i) Understand the 4 Principles of FY91Q Autonomous Flight
  - ii) GPS & Compass Set Up (Field Calibration)
  - iii) GPS Satellite Detection

### i) The 4 Principles of FY91Q Autonomous Flight

The FY91Q has four unique autonomous flight principles which is different from any other multirotor system. Failure to understand these 4 Principles will result in failure to achieve autonomous flight.

#### **1<sup>ST</sup> PRINCIPLE: HOVER USING YOUR TRANSMITTER TRIMS**

1. The FY91Q is a 3 gyro / 3 accelerometer stabilizer system mounted on a flat platform (board). This platform is mounted in an aluminum box.
2. The positioning of these 6 sensors varies from one FY91Q module to another (no two modules are exactly the same). Furthermore, mounting of the module on the aircraft may result in tilting to one side.
3. Therefore, a less than leveled Axis will always occur. Example:

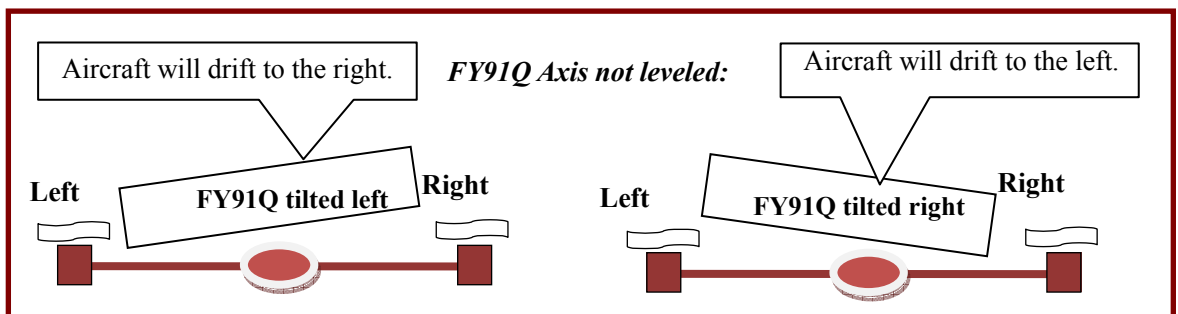

4. To solve this, install your FY91Q as leveled as possible on your aircraft. Then hover your aircraft in Stabilized Mode (Mode 1) and use your transmitter trims (Aileron and Elevator only) to get it to hover almost hands free.
5. If you note too much trim is used, reinstall your module by shimming the mounting. Hover again and you should note a reduction in trimming used. Example:

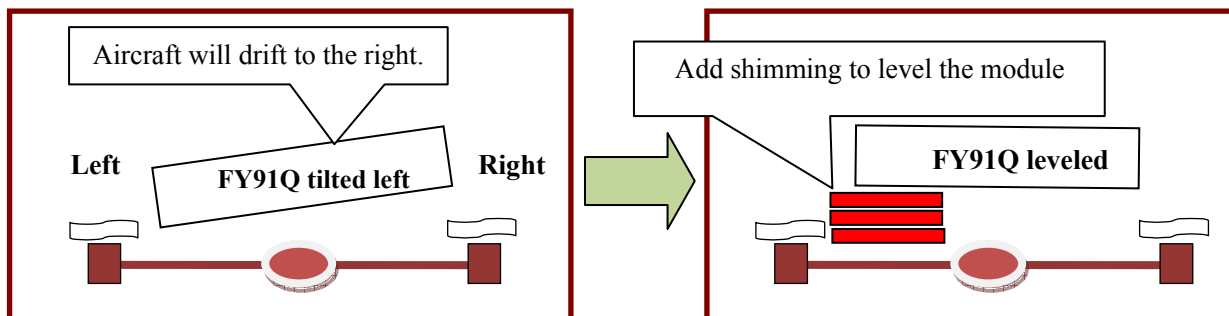

6. By the same principle, if there is a directional wind which is causing drift to the aircraft, use your transmitter Aileron and Elevator trims to counter this wind drift.
7. Note that every flight will require some trimming adjustment.
8. **IMPORTANT:** Note that the Rudder trims are **not used** in this procedure. Keep your rudder trims in the middle. (If your rudder trims is not set in the middle, RTH flight direction will not be straight).
9. **Reminder:** Other than the throttle stick to maintain altitude, you do not use your sticks to hover the aircraft. Use only your Aileron and Elevator trims. This is the ***First Principle***.

## **2<sup>ND</sup> PRINCIPLE: THE FLIGHT NEUTRAL GAIN**

1. This second principle does not require you to do anything, other than to fully understand it.
2. Every time an FY91Q is airborne, there are two controlling gains that is interdependent and yet opposing to each other:

**Controller Gain 1:** The automated FY91Q flight controller gain, produced by the 6 sensors to maintain the aircraft in a leveled state.

**Controller Gain 2:** The user manual gain (that's you), which controls the aircraft in manual flight via your transmitter sticks.

3. After you have implemented Principle 1 (hover by transmitter trims), then in Principle 2, the two gains function purely to oppose each other; the controller will try to oppose any instability of the aircraft, while the pilot (you) via the transmitter stick commands, will make the aircraft 'unstable' so that it can be moved to any position in the sky.
4. If you have fulfilled the 1<sup>st</sup> Principle, letting go of the transmitter sticks (Aileron, Elevator, Rudder), will return the aircraft to a leveled flight state.
5. This leveled flight state with no input from the pilot is called the **Flight Neutral Gain** or Neutral Value.
6. **MOST IMPORTANTLY**, note that other than your throttle stick, when in Flight Neutral Gain your transmitter sticks are **ALL** in the middle position.
7. Pause here and think about it.
8. Note that Throttle control is fully manual at all times. Flight Neutral Gain does not involve the throttle channel.

### **3<sup>rd</sup> Principle: FY91Q LEARNS ON-THE-FLY FOR HOVER HOLD**

1. A quick Recap:

**Principle 1** = FY91Q can hover using only trims. Throttle maintains altitude.

**Principle 2** = Hovering Hands free is the point of **Flight Neutral Gain**

2. **3<sup>rd</sup> Principle** = the FY91Q will 'learn' your Flight Neutral Gain **every time** you activate Hover Hold (Mode 2).
3. However, this 'learning' process can only occur if you release all control sticks (Aileron, Elevator, Rudder) and leave **them in the middle position**.
4. The Flight Neutral Gain (hands free hover) must be achieved before the FY91Q can 'learn' the hover setting and engage Hover Hold.
5. The learning process and engaging Hover Hold takes about 2 seconds.
6. The moment you input any control movement via Aileron / Elevator or Rudder, FY91Q will disengage Hover Hold and the aircraft is in your manual control again.
7. Please also note that when you engage the Hover Hold Switch, **FY91Q also acknowledges your throttle level**. Therefore, it is critical that you engage Hover Hold only after you have set the throttle level for hovering.
8. If you engage Hover Hold while the aircraft is descending (throttle too low) or ascending (throttle too high), FY91Q will set that throttle level as the hover throttle level. This will result in your aircraft continuing its descent or ascent movement in Hover Hold.

#### 4<sup>th</sup> Principle: THROTTLE IS THE KEY

1. An additional requirement to engage Hover Hold is Throttle signal. FY91Q will only engage Hover Hold and RTH functions if you put the throttle stick to the middle position (outputting 1400 to 1600  $\mu$ S signal).
2. Therefore, after you switch to Hover Hold, you **must move** the throttle stick to the middle position right after switching.
3. To be clear, here's the 6 steps to achieve Hover Hold:
  - a) Fly your aircraft to a safe height and distance.
  - b) 'Hands free' hover your aircraft, controlled only by using your transmitter Aileron & Elevator trims. Throttle maintains altitude.
  - c) Activate Hover Hold Switch (Mode 2)
  - d) Move your throttle stick up or down so that it is brought to the middle position.
  - e) FY91Q takes the throttle signal (middle position) as confirmation to engage Hover Hold.
  - f) Aircraft will hover holding its position and altitude.
4. In most transmitters, the throttle signal of 1400 – 1600  $\mu$ S range is when you have a straight throttle curve. Please ensure your throttle curve is straight:

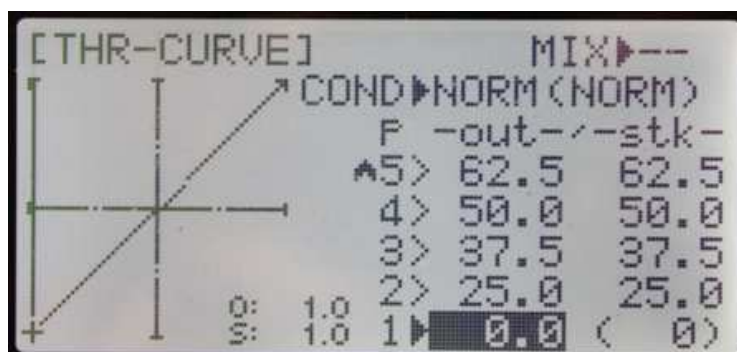

## ii) **GPS & COMPASS MODULE SET UP (MANGETOMETER CALIBRATION)**

1. The GPS & COMPASS Module contains an internal three-axis magnetometer. This module senses the earth's magnetic field, and uses this reading to accurately measure the aircraft direction of flight.
2. The magnetometer sensor is very sensitive to metallic objects and electric fields. Keep such objects as far away from the module as possible.
3. Before each flight, it is best to do a field calibration. With practice it is very easy to do (takes only 20 seconds).
4. Field calibration enables the GPS & Compass Module to calibrate for the environment in which it is installed.
5. Field calibration should also be done if new equipment is installed which may affect the magnetic field around the aircraft.
6. Field calibration process:
  - a) Place the aircraft on flat ground.
  - b) Continuously change (toggle) the flight modes between Mode 1 (Stabilized Mode) to Mode 2 (Hover Hold) six times:
    - (1) **balance mode** -> Hover Hold – (2) **balance mode** -> Hover Hold –
    - (3) **balance mode** -> Hover Hold – (4) **balance mode** -> Hover Hold –
    - (5) **balance mode** -> Hover Hold – (6) **balance mode**
  - c) Observe the blue LED go OFF after you toggle 6 times. This indicates the FY91Q has entered the Field Calibration Mode.
  - d) After the Blue LED goes OFF, move the aircraft slow and steady in a clockwise rotation one and a half times. The rotation should be done slowly, taking

approximately 15 seconds to complete. If you do it too fast, calibration will fail (Blue LED will not light up), and you have to do it all over again.

- e) After this rotation, the blue LED will light up again, indicating Field Calibration is complete.
- f) Proceed to into GPS Detection.

### **iii) GPS DETECTION (HOME LOCK)**

- a) GPS is required to enable autopilot flight positioning.
- b) Ensure you are outdoors to maximize GPS satellite detection (minimum 5 required).
- c) Upon power up, the FY91Q will automatically search for GPS satellites.
- d) Upon detecting 5 satellites, the red LED will begin flashing twice continuously, indicating GPS Home Position has been locked.
- e) You can safely fly the FY91Q system without GPS locking 'home' position (red LED flashing twice). However, both Hover Hold and RTH autonomous flight **cannot** function.
- f) Without GPS lock, the FY91Q can only hold altitude if Hover Hold is activated. Position hold cannot be activated, and therefore the aircraft will drift randomly.
- g) If during the RTH function GPS lock is lost, the aircraft will stop moving and begin to drift randomly. However, it can still fly while maintaining altitude.

## **HOVER HOLD AND AUTOMATIC RETURN TO HOME TESTING**

1. After carrying out the above Setting Up procedures and confirmation of 5 satellite detection (red LED double flashing continuously) you can proceed with Hover Hold and RTH testing.
2. We recommend carrying out the first autonomous flight tests in light winds (wind speed less than 3 mph).
3. Implement the 4 Principles of FY91Q Autonomous Flight.
4. After successfully engaging Hover Hold (at least 2 seconds), you may proceed to test the RTH function.
5. Move the aircraft to any location (not too far in the first few tests) in Stabilized Mode, when you switch to RTH Mode, the aircraft should automatically fly back to Home position while maintaining current altitude.
6. Upon reaching the Home position, the aircraft will automatically activate Hover Hold (maintaining position and altitude).
7. Again, note that FY91Q must have successfully recorded your hover benchmark (setting Aircraft Neutral Gain) to execute RTH. Failure which, the RTH function will not work.

## **ADDITIONAL NOTES ON RETURN TO HOME (MODE 3)**

1. For FY91Q autonomous RTH flight, similar principles to Hover Mode is utilized, with differences in critical areas. These are:
  - (a) RTH utilizes **the last recorded** Flight Neutral Gain value.
  - (b) RTH will only activate after the aircraft has stabilized into a hover.

- (c) There is a timed delay (between 2 to 5 seconds) between activation of RTH and the actual procedure of returning to the home position. This delay is to stabilize the aircraft into a hover before proceeding with RTH.
  - (d) Note that due to (c) above, if your aircraft is moving forward during the time of RTH engagement, it will not stop immediately. Time is required for it to be stabilized into a hover before proceeding with RTH function.
2. Due to the reason (a) above, we highly advise that you carry out the Hover Hold procedure (Principles 1, 2, 3 and 4) **at the start of every flight** so that the FY91Q has a record of your latest Neutral Gain value in case RTH needs to be engaged.
  3. Engage the Hover Mode Switch for at least 2 seconds for the system to learn and record your latest Neutral Gain values.

### FLIGHT PARAMETER ADJUSTMENT SOFTWARE

The FY Tech FY91Q Parameter settings interface is as shown below:

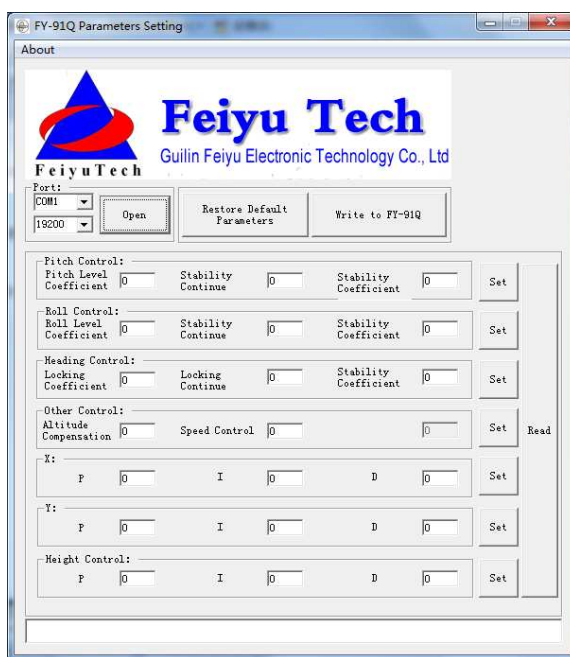

## Flight Parameter Adjustment Software – SAFETY FIRST!

1. The default FY91Q settings have been adjusted for optimal stability and flight performance. The flight parameter adjustments provided via the ***FY Tech Flight Parameters Setting*** software should only be done by very experienced multirotor pilots who need to further **fine tune** the aircraft characteristics.
2. We do not recommend adjusting the flight parameters without a specific fine tuning target.
3. **Safety Warning 1:** A Wrongly Adjusted Flight Parameter Setting may result in extreme aircraft instability and crash. Do a tie down test when adjusting Flight Parameters for the first time.
4. **Safety Warning 2:** If you are powering the FY91Q via your onboard BEC, make sure you take off the red wire as shown below. Failure to do so may result in damage to both your computer and FY91Q. Additionally, if you are powering the FY91Q via your ESC BEC, make sure you tie down your aircraft or take off the propellers to prevent possible accidental injuries.

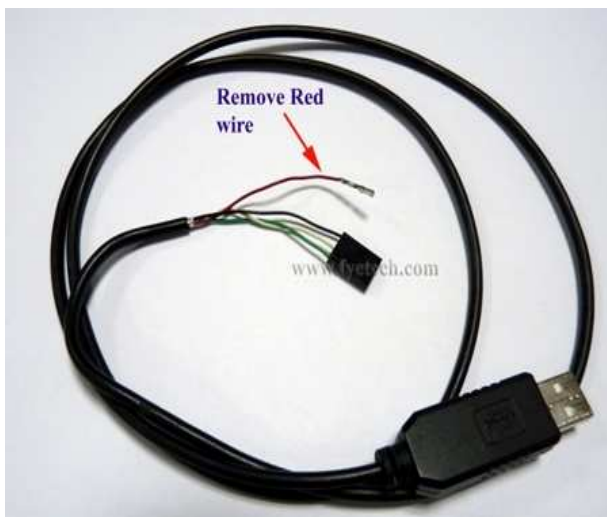

Remove Red wire if using the on board ESC BEC to power up the FY91Q. Failure to do this can result in damage of your PC and FY91Q.

5. Hardware requirements:

- a) Portable PC / Laptop with USB port.
- b) USB – TTL Cable
- c) Download and install the USB-TTL Drive. Download site:  
<http://shop.fyetech.com/dl/ttldriver.rar>
- d) Download and install the FY91Q Parameters Setting Software. Download site:  
**(Link to be released later)**

6. Setting adjustment procedure:

- a) Connect USB-TTL cable to the computer.
- b) Connect the USB TTL cable to the FY91Q UART data port as shown below:

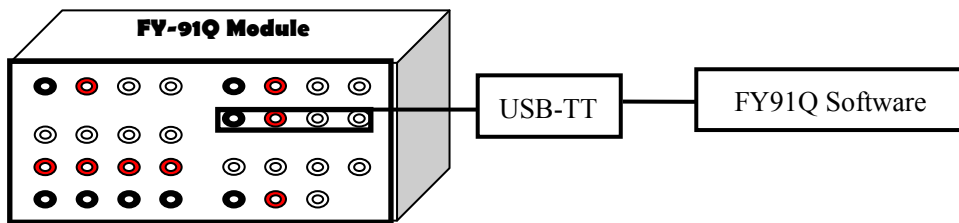

- c) Open the FY91Q Parameters adjustment software. Select the appropriate USB port number (check via your computer Device Manager) and set the baud rate to 19200.



d) Click "Open" to connect to your FY-91Q.



e) Click "Read" to see the existing parameters:

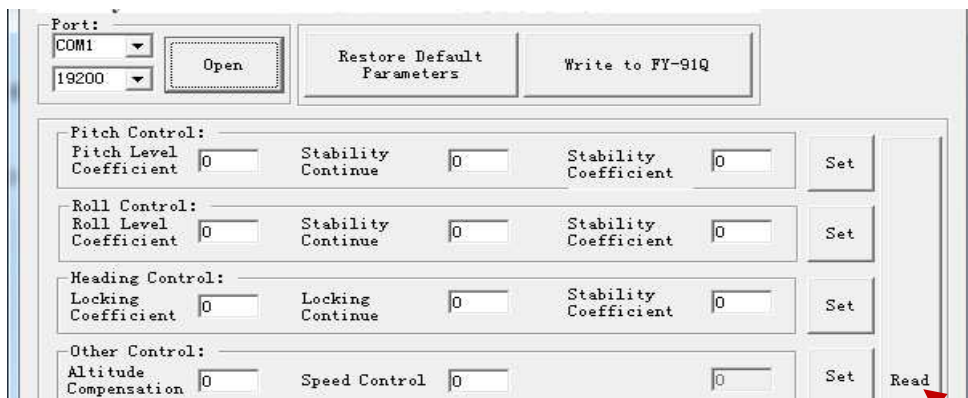

f) Flight parameter settings:

	<b>Pitch level coefficient</b>	<b>Stability Continue</b>	<b>Stability coefficient</b>
<b>Pitch control</b>	This setting controls the amount of pitch automatic recovery.	Stability level adjustments. Reduce until oscillations stops.	A higher value makes the respond stronger to prevent pitch angle changes. Generally larger / heavier aircraft require higher value.
<b>Roll control</b>	This setting controls the amount of roll automatic recovery.	Stability level adjustments. Reduce until oscillations stops.	A higher value makes the respond stronger to prevent roll angle changes. Generally larger / heavier aircraft require higher value.
<b>Heading control</b>	This setting controls the amount of heading (yaw) lock stability.	Controls the amount of integral yaw control. Too high will lead to oscillations.	A higher value makes the respond stronger to prevent heading (yaw) changes.

**g) Additional setting adjustments:**

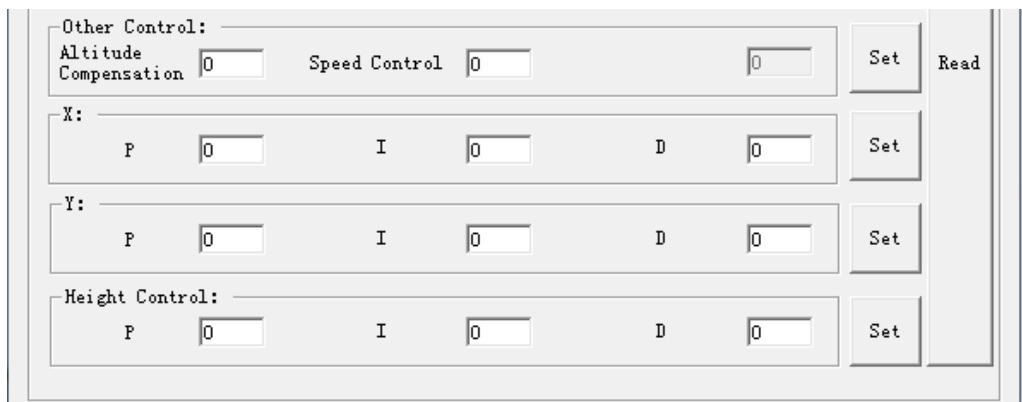

**a. Altitude compensation:** This parameter controls the sensitivity of the FC to automatically increase or decrease throttle level to compensate for altitude loss during aircraft tilt recovery. Example: If you observe the aircraft lose altitude during tilt recovery, increase the value of this parameter.

**b. Speed control:** Increase or decrease this value to adjust the sensitivity to forward flight (speed) of the FC.

**c. PID Settings:**

	<b>P</b>	<b>I</b>	<b>D</b>
<b>X</b>	Control the amount of lateral deviation.	Integral control the amount of lateral deviation.	Control the amount of lateral deviation change
<b>Y</b>	Control the amount of vertical deviation	Integral control the amount of vertical deviation	Control the amount of vertical deviation change
<b>Height control</b>	Control the amount of height variation	Integral control the amount of height variation	Height deviation change degree of control.

- h) After setting adjustment, confirm the new parameters by clicking the “Set” button. Clicking the “Set” button will send the new setting to the FY91Q.
- i) Click to “Read” button to confirm the changes have been saved.
- j) Finally, click the "Write to FY-91Q" button to permanently save the new settings in the FY-91Q. If this button is not pressed, the new parameters will be lost when you power-down the FY91Q.

**k) Return to Default Setting**

If you feel at any time you wish to return to the factory settings, simply click on “Restore Default Parameters”. The factory default settings will be displayed. Click on all the “Set” buttons, before pressing “Write to FY-91Q”.

**FY91Q Ground Control Station Function**

1. The FY91Q the UART interface can be connected to the FY digital Data Radio, such as FY606 (2.4 Ghz) and FY602 (433 MHz) for bidirectional communication between your field PC (GCS) and the FY91Q autopilot.
2. You will require to download the latest FY-GCS software to utilize the GCS function of the FY91Q.
3. FY-GCS enables you can display the onboard autopilot telemetry data on to your GCS display, including the GPS position of the aircraft on Google Map.
4. You can remotely adjust the flight parameters of the FY91Q via the GCS software.

We will release more information about this feature in future FY91Q manual updates.

5. Data radio Parameters:

FY91Q interface panel have 4 Pin for UART	<b>GND, Power, TX1, RX1</b>
Baud rate	<b>19200</b>
Interface characteristic	<b>TTL</b>

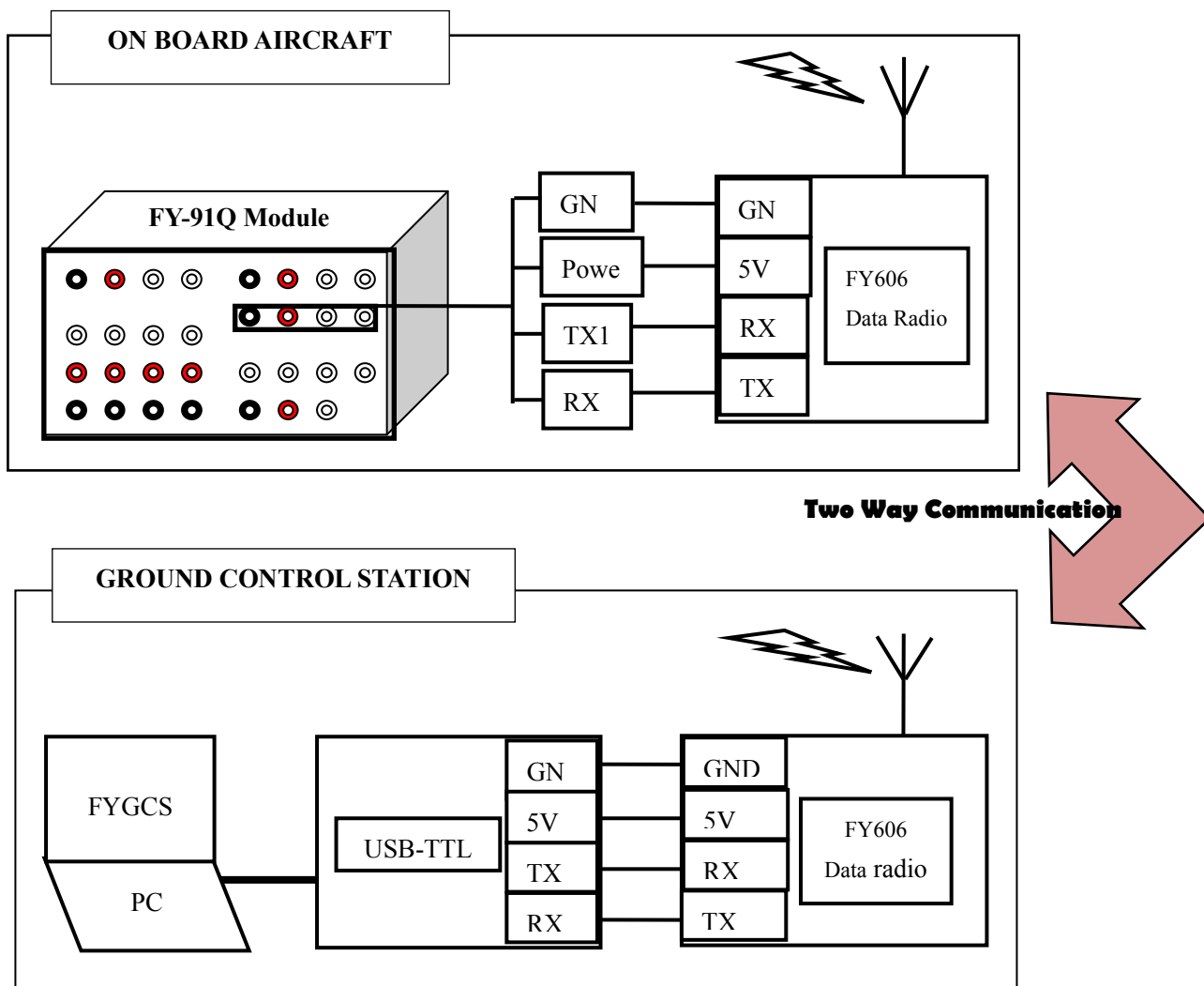

6. Refer to FY606 Manual on more details on the FY606 (to be updated).
7. Refer to FYGCS Manual on more details of the FYGCS (to be updated).

## FY91Q Connection to AP117 ON SCREEN DISPLAY

1. You can connect the FY91Q to the AP117 OSD module to display the telemetry data onto your On Screen Display.
2. Connection is as shown below:

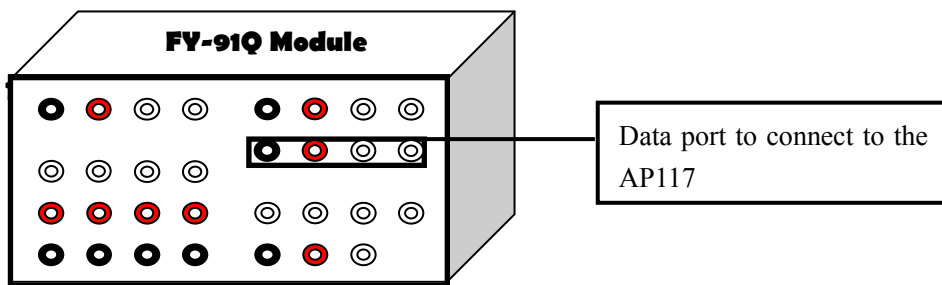

Refer to AP117 Manual on more details of the display.

<http://shop.fyetechnology.com/dl/ap117.pdf>

<b>Flight Modes</b>	<b>Mode 1</b> <i>(Stabilized Mode)</i>	<b>Mode 2</b> <i>(Hover Hold)</i>	<b>Mode 3</b> <i>(RTH Mode)</i>
<b>AP117 Display</b>	<b>ABM</b>	<b>FAF</b>	<b>RTL</b>

## **UPGRADING THE FY91Q FIRMWARE**

Firmware update procedure to be explained in Draft 7 of this FY91Q Manual.

## **FY91Q / FY90Q BASIC SYSTEM REQUIREMENTS**

### **Electronic Speed Control (ESC) Requirements:**

1. ESCs that can handle an input signal pulse frequency over **400Hz is a must**.
2. Use only ESCs that has a manually settable throttle end points. All endpoints **MUST** be manually matched.
3. ESCs with Fast response rates are recommended (high and mid timing settable). Too slow response will result in failure to maintain Quad flight stabilization and control.
4. Do not use ESCs that lose their throttle endpoint settings at each power off (e.g. Castle Thunderbird series).
5. **Do not use** ESCs that must be "armed" before you can set the throttle endpoints (Castle Thunderbirds, Hobby King SS ESCs, etc.). With this ESC type, you must power up all motors and go to full throttle to set the endpoints, making it impossible to use on multirotors.

### **Pre-Flight Check & Sensitivity (Exponential) Adjustment**

#### **STEP 1 - Radio Transmitter Settings**

- I. Select the Model for Traditional Airplane, where there is **no mixing** of the throttle, elevator, aileron or rudder controls.
- II. For transmitters with helicopter settings only, choose mCCPM model setup where throttle, pitch, elevator, aileron and rudder are not mixed.
- III. For a start, we recommend you use your Transmitter EXPO to reduce control responsiveness by 50 percent for Aileron and Elevator.

**IV.** If the throttle responsiveness is too high, use EXPO to reduce this too.

**V.** For rudder, we recommend no EXPO setting (keep at normal).

## **STEP 2 – Matching ESC End Points**

- (a) Only use ESCs that you can manually set the throttle endpoints. All endpoints **MUST** be manually matched.
- (b) To manually match your ESC endpoints, refer to your ESC Manual.
- (c) As a general guide to ESC end point matching, carry out the following:
  - i. Install the FY90Q/FY91Q, 4 x ESCs and 4 x motors as directed in the manual.
  - ii. For added safety, remove all four propellers.
  - iii. Ensure your radio Transmitter is set up as in STEP 1 above.
  - iv. Activated your radio and set throttle to maximum - be sure that throttle endpoints are set at more than 100%.
  - v. Power up the quad, therefore activating your RC Receiver, FY90Q / FY91Q and ESCs.
  - vi. All four ESCs should give out the signal of detecting the maximum throttle level.
  - vii. Push down your throttle.
  - viii. All four ESCs should give out the signal of detecting the minimum throttle level.
- (d) If your ESC do not show detection of the Maximum and Minimum throttle levels, please check with your ESC manual on the correct procedure.
- (e) If this procedure is successful, proceed with flight tests as per the manual.

## **ESC; Not Arming**

1. Many types of ESCs have an arming protection set up where they expect to see an incoming signal as soon as they are powered up. If the ESC do not 'see' this input signal, it will automatically inhibit the arming process.
2. Upon powering up, the FY91Q takes about 1 to 2 seconds to initialize. During this time, signal is not immediately sent to the ESCs. Due to (1) above, the ESC will not arm even after the FY91Q begins sending signal to the ESC.
3. As a result, the ESC refuses to arm.
4. To confirm this, carry out the following:
  - (a) **Remove all your ESC red wire** (positive) connection to the FY91Q.
  - (b) Install an external BEC (at least 3A output).
  - (c) Turn ON your Radio Transmitter and set the minimum to -30%.
  - (d) Power up the FY91Q and your RC receiver via the external BEC, but NOT the ESCs.
  - (e) After the FY91Q initializes, power up your ESCs.
  - (f) Decrease your throttle to - 100 until the ESC arms.
  - (g) This proves your ESC has the delayed activation protection.
5. An easy set up to solve this is to have a two plug power up system. i.e. power up your BEC first, before powering up your ESCs.

**END OF DRAFT 6 FY91Q MANUAL Dated 7<sup>th</sup> JULY 2011**